

Roll
No.

--	--	--	--	--	--	--	--	--	--	--

Serial No. of
Q. C. A. B.

ಒಟ್ಟು ಪ್ರಶ್ನೆಗಳ ಸಂಖ್ಯೆ : 5]
Total No. of Questions : 5]

[ಒಟ್ಟು ಮುದ್ರಿತ ಪುಟಗಳ ಸಂಖ್ಯೆ : 12
[Total No. of Printed Pages : 12

ಸಂಕೇತ ಸಂಖ್ಯೆ : **72**

ವಿಷಯ : ಇಂಜಿನಿಯರಿಂಗ್ ಡ್ರಾಯಿಂಗ್

Code No. : **72**

Subject : **ENGINEERING DRAWING**

ದಿನಾಂಕ : 23. 06. 2012]

[Date : 23. 06. 2012

ಸಮಯ : ಮಧ್ಯಾಹ್ನ-2-00 ರಿಂದ 5-15 ರವರೆಗೆ]

[Time : 2-00 P.M. to 5-15 P.M.

ಪರಮಾವಧಿ ಅಂಕಗಳು : 50]

[Max. Marks : 50

FOR OFFICE USE ONLY

Q. No.	Marks	Q. No.	Marks	Q. No.	Marks	Q. No.	Marks	Q. No.	Marks
1.		×		×		×		×	
2.		×		×		×		×	
3.		×		×		×		×	
4.		×		×		×		×	
5.		×		×		×		×	
×		×		×		×		×	
×		×		×		×		×	
×		×		×		×		×	
×		×		×		×		×	
×		×		×		×		×	
×		×		×		×		×	
×		×		×		×		×	
×		×		×		×		×	
×		×		×		×		×	
Total Marks									
Total Marks in words							Grand Total		
1. ✓									
2. ✓						✓		✓	
Signature of Evaluators			Registration No.			Signature of the Deputy Chief		Signature of the Room Invigilator	

[Turn over

General Instructions :

- i) The Question-cum-Answer Booklet consists of objective and subjective types of questions having 5 questions.
- ii) Space has been provided against each objective type question. You have to choose the correct choice and write the complete answer in the space provided.
- iii) For subjective type questions enough space for each question has been provided. You have to answer the questions in the space.
- iv) Follow the instructions given against both the objective and subjective types of questions.
- v) Candidate should not write the answer with pencil. Answers written in pencil will not be evaluated. (Except Graphs, Diagrams & Maps)
- vi) In case of Multiple Choice, Fill in the blanks and Matching questions, scratching / rewriting / marking is not permitted, thereby rendering to disqualification for evaluation.
- vii) For reading the questions 15 minutes of extra time has been provided.

Instructions :

- i) Answer *all* the questions.
- ii) Retain the constructional details.
- iii) All dimensions are in mm.
- iv) Use first angle projection only.
- v) Missing dimensions may be assumed.
- vi) All drawings should be drawn in drawing sheet only.

1. a) Fill in the blanks with the correct figure/word(s) by selecting from the choices given in the brackets : 5 × 1 = 5

- i) view is the main principal view of the object.

(*Top, Front, Profile*)

Ans : _____

- ii) is the inner most part of a thread.

(*Root, Crest, Flank*)

Ans : _____

iii) The shape of reflectors designed to focus light to a point will be

(*parabolic, elliptical, hyperbolic*)

Ans : _____

iv) Drawings of small machine parts to be drawn to a scale.

(*same, enlarged, reducing*)

Ans : _____

v) threads are used in railway carriage couplings.

(*Acme, Knuckle, Buttress*)

Ans : _____

b) Match the following :

5 × 1 = 5

Group A

Group B

- | | |
|--------------------------|---------------------------------|
| i) Ellipse | a) three equal sides |
| ii) Parabola | b) two equal sides |
| iii) Hyperbola | c) unequal sides |
| iv) Equilateral triangle | d) eccentricity one |
| v) Isosceles triangle | e) eccentricity $\frac{2}{3}$ |
| | f) eccentricity $\frac{3}{2}$. |

Ans :

i) _____

ii) _____

iii) _____

iv) _____

v) _____

[Turn over

2. a) Print the given word in single stroke inclined capital letters of height 18 mm with ratio 6 : 5. 5

'PARABOLA'

- b) Construct a plain scale to read centimetre and decimetre and long enough to measure 6 decimetre, when R.F. = $\frac{1}{4}$, show on it a distance of 4.9 decimetre. 5

3. a) Inscribe an ellipse in a rectangle of 130×80 mm.

- b) Construct a parabola in a parallelogram of sides 100 mm \times 45 mm and with an included angle of 75°. 5

4. Draw the involutes of a circle of diameter 40 mm. Also draw a tangent and normal at any point on the curve. 10

OR

The pictorial view of an object is shown in figure No. 1. Draw the following orthographic views and mark the dimensions : 10

- (i) Front view — Looking in the direction of arrow 'X'
- (ii) Top view — Looking in the direction of arrow 'Y'
- (iii) Side view — Looking in the direction of arrow 'Z'.

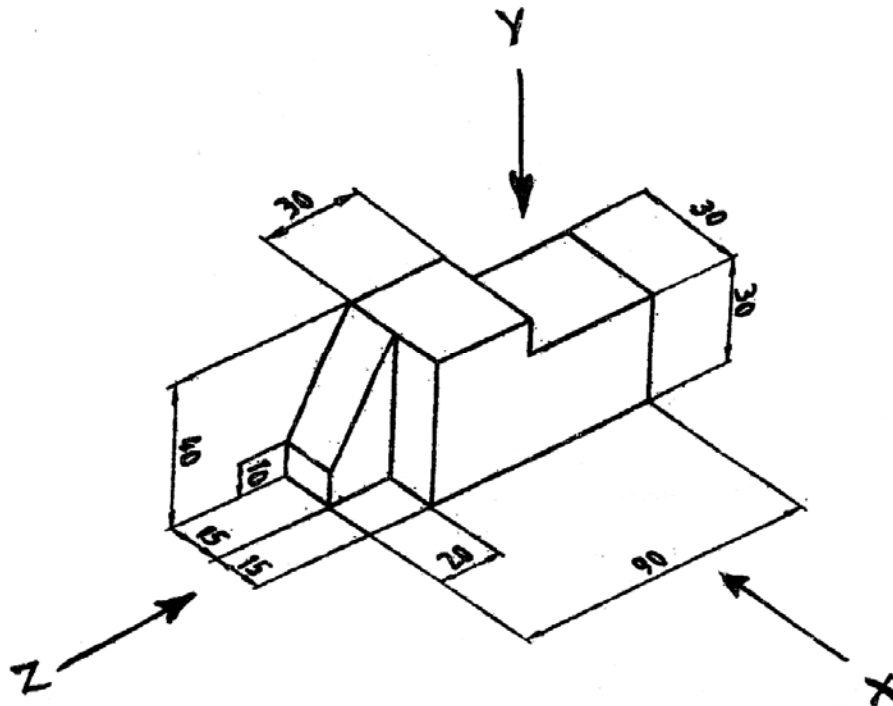

Figure No. 1

